

WILLBRANDT Rubber Expansion Joint Type 57

DN 50 - DN 300

Type 57 is a conical or eccentric rubber expansion joint that achieves very low flow resistance because of its uncorrugated bellow geometry. It is suitable for conveying media that contain solids, even at high flow rates. It is also characterised by its variety of rubber qualities, which means that a suitable rubber compound is available for every application (see material descriptions on the following pages). Its design means that it can only absorb minimal (axial) compression! Alternative production lengths are possible in individual cases and subject to agreement.

Type 57 is used in plant engineering, water technology and wastewater technology to absorb lateral movement, as well as to absorb vibration and insulate sound.



Bellow design	Smooth conical/eccentric rubber bellow with reinforcement and moulded sealing bead with core ring (self-sealing - no additional seals required). Suitable for accommodating swiveling flanges.	Flange version	Both sides with swiveling flange made of galvanized steel, with clearance holes, drilled according to DIN PN 10 (standard). Other materials and dimensions are possible.
Vacuum resistance	Only vacuum-resistant with a vulcanised vacuum supporting spiral.	Accessories	<ul style="list-style-type: none"> - Potential equalisation - Flame-resistant protective covers - Dust and splash protection covers - Earth cover / sun protection hoods - Segment tie rods
Approvals/Conformity	Drinking water approval, FDA and EG 1935/2004 conform		

Specifications

Bellow		Bellow design			Max. temperature °C	Permissible operating data									
Colour code	Colour marking	Core (inner)	Reinforcement	Cover (outer)		°C	bar	°C	bar	°C	bar	°C	bar	°C	bar
red		EPDM	Polyamide	EPDM	100										
blue		EPDM TW	Polyamide	EPDM	100										
white/red		EPDM beige	Polyamide	EPDM	100										
red		EPDM AF	Polyamide	EPDM	100										
green		CSM	Polyamide	CSM	100										
yellow-grey		NBR	Polyamide	CR	100										
white-grey		NBR beige	Polyamide	CR	100										
grey		CR	Polyamide	CR	90										
red-blue-red		EPDM	Aramid	EPDM	100										
blue-blue-blue		EPDM TW	Aramid	EPDM	100										
white-blue-red		EPDM beige	Aramid	EPDM	100										
orange-blue-orange		EPDM HT	Aramid	EPDM HT	125										
red-blue-red		EPDM AF	Aramid	EPDM	100										
green-blue-green		CSM	Aramid	CSM	100										
yellow-blue-grey		NBR	Aramid	CR	100										
white-blue-grey		NBR beige	Aramid	CR	100										
grey-blue-grey		CR	Aramid	CR	90										
lilac-blue-lilac		FPM	Aramid	FPM	180										
-	-	Silicone	Aramid	Silicone	180										
-	-	Silicone	Glass fabric	Silicone	200										

Important information

For aggressive media, please see the resistance table (can be requested separately).
 The bellows should not be painted or insulated. Please refer to the installation instructions.
 ++++ We will be happy to send you further information on the individual types and designs. ++++

WILLBRANDT Rubber Expansion Joint Type 57

Application

Type 57 red (EPDM)

For water, sea water, cooling water with glycol or other chemical additives for treating water, saline solutions, weak acids and weak alkali solutions. Unsuitable for aliphatic, aromatic and chlorinated hydrocarbons, oil or oily media.

Type 57 blue (EPDM TW)

Like Type 57 red, but approved for drinking water.

Type 57 white-red (EPDM beige)

Like Type 57 red, but with light-coloured rubber in food-grade.

Type 57 red AF (EPDM AF)

Like Type 57 red, but with abrasion-resistant EPDM rubber compound.

Type 57 green (CSM)

For chemicals, aggressive, chemical wastewater and compressor air containing oil.

Type 57 yellow-grey (NBR)

For oils, fats, gases, diesel fuels, kerosene and crude oil. Not suitable for aromatic and chlorinated hydrocarbons, esters and ketones.

Type 57 white-grey (NBR beige)

Like Type 57 yellow-grey, but with light-coloured internal rubber in food-grade. Not approval for drinking water!

Type 57 grey (CR)

For water, wastewater, swimming pool water, salt water, cooling water with anti-corrosive products containing oil, oil mixtures and compressed air containing oil.

Type 57 red-blue-red (EPDM/aramid)

Like Type 57 red, but with aramid fabric.

Type 57 blue-blue-blue AF (EPDM TW/aramid)

Like Type 57 blue, but with aramid fabric.

Type 57 white-blue-red AF (EPDM beige/aramid)

Like Type 57 white-red, but with aramid fabric.

Type 57 orange-blue-orange AF (EPDM HT/aramid)

Like Type 57 red, but with aramid fabric and for temperatures up to +125 °C

Type 57 red-blue-red AF (EPDM AF/aramid)

Like Type 57 red AF, but with aramid fabric.

Type 57 green-blue-green (CSM/aramid)

Like Type 57 green, but with aramid fabric.

Type 57 yellow-blue-grey (NBR/aramid)

Like Type 57 yellow-grey, but with aramid fabric.

Type 57 white-blue-grey (NBR white/aramid)

Like Type 57 white-grey, but with aramid fabric.

Type 57 grey-blue-grey (CR/aramid)

Like Type 57 grey, but with aramid fabric.

Type 57 lilac-blue-lilac (FPM/aramid)

For flue gas desulphurisation systems and bio-diesel. High chemical resistance to benzene, xylene, toluene, aromatic, chlorinated hydrocarbons, mineral acids and fuels with an aromatic content of more than 50 %. For temperatures of up to 180 °C.

Type 57 silicone (silicone/glass fibre or aramid)

Suitable for hot air, acetic acid. Satisfactory resistance to aliphatic engine and gear oils. Also available in foodstuff quality. Excellent resistance to ageing, UV, ozone and weather. Very good radiation resistance. Not for use with steam above 120 °C. No resistance to fuels.

Note!

Detailed material descriptions on pages 5 - 7.



WILLBRANDT Rubber Expansion Joint Type 57

Design A - concentric, without tie rods

Can be used to absorb compression and lateral movement, as well as to insulate vibration and sound.
Can only absorb minimal expansion.

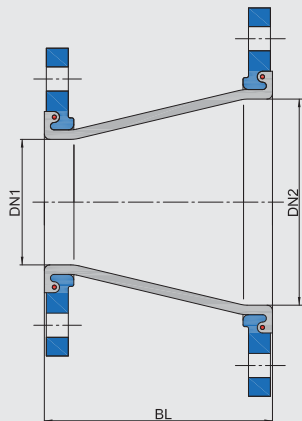

Design A - eccentric, without tie rods

Can be used to absorb compression and lateral movement, as well as to insulate vibration and sound.
Can only absorb minimal expansion.

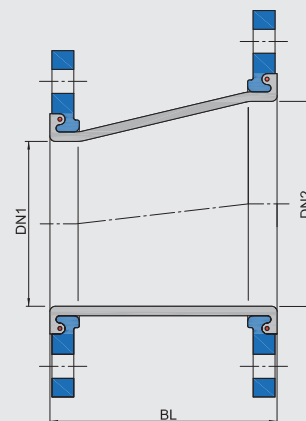

Dimensions for Design A Concentric/eccentric

DN1	DN2	Length BL mm	Bellow WF* mm ²	Movement absorption	
				axial - mm	lateral ± mm
50	80	250	5000	3	8
50	100	250	7900	3	8
65	80	300	5000	3	8
65	100	300	7900	3	8
80	100	250	7900	3	8
80	125	250	12300	3	7
100	125	250	12300	3	7
100	150	250	17700	3	7
100	200	300	31400	3	7
125	150	250	17700	3	7
125	200	300	31400	4	8
150	200	300	31400	4	8
150	250	250	49100	5	8
200	250	250	49100	4	8
200	300	300	70700	6	8
200	350	300	96200	9	12
250	300	300	70700	4	7
250	350	300	96200	6	9
300	350	300	96200	4	7
300	400	400	125600	7	9

* WF = effective area

- Movement absorption is for a bellows design with 6 bar operating pressure.
- Free choice of flange connection dimension (DIN, ASTM, JIS, etc.)
- Special overall lengths and nominal diameters are possible in individual cases.

Length limiters/Tie rods

It is advisable to use tie rods/shear limiters on these expansion joints (Design M - see illustration). The conical bellows is inflated by the rise in pressure, which shortens the expansion joint and applies high tensile force to the connections.

It is also available with tie rods only (Design E).

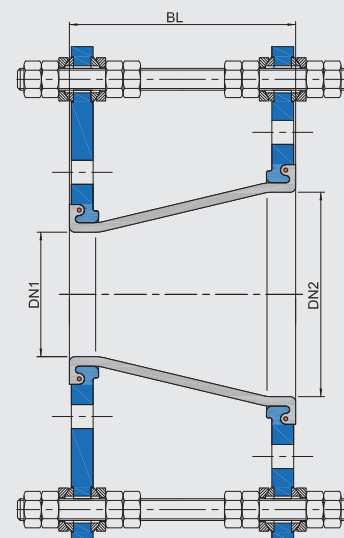

Important information

Please note the appropriate fixed point constructions and plain bearings in your piping system, as well as the tolerances as per the FSA Handbook (see the technical appendix on page 118)!

For more information please refer to our installation instructions (p. 97 - 116).

++++ We will be happy to send you further information on the individual types and designs. +++++